

Optimising Wind Turbine Cable Installation

TOWL Integrated Pull In Module (PIM)



Mike Kearney- Senior Project Engineer, Lincs Project,
Technip Offshore Wind Ltd
Subsea UK 2012 Conference - AECC

Technip Offshore Wind Ltd

AMT Discoverer



UR141



Our Vision

To be the reference company for cable installation solutions in the European offshore renewable market

UR1



CBT1100 Due 2012



Sea Stallion Ploughs



HD Plough due 2012





TOWL Pull In Module

- 1. The challenge**
- 2. Historical methodology**
- 3. Process weaknesses**
- 4. Solution development**
- 5. TOWL Pull In Module**
- 6. Offshore implementation**
- 7. Summary**

PIM is a protected concept unique to TOWL Cables Division

The challenge

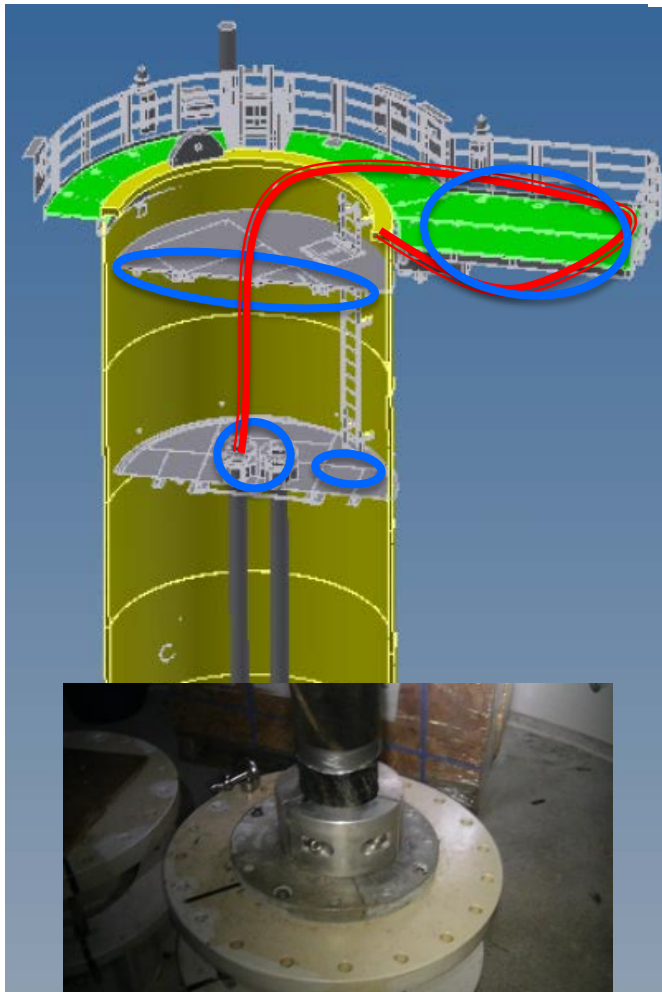

Scope on Lincs & previous projects

- Expected pull in loads of 3.5T
- Exposed cables pulled through a subsea J-tube to hang-off flange
- No internal hang off points
- Pull in typically blind
- No strong points or bolt patterns on landing platform
- Cables pulled in beyond hang off for termination
- Weak internal deck levels
- Over put stored inside or on external landing platform
- Weak J-tube mounting flange
- Cables then suspended on hang off clamp

* TP -LS41 Lincs Wind Farm the Wash Lincolnshire

Historical methodology

Timeline

- Personnel access the TP via crew boat
- Basic tripod structure landed on TP
- Series of crane lifts to transfer equipment
- Vessel winch wire is routed through the J-tube as follows...

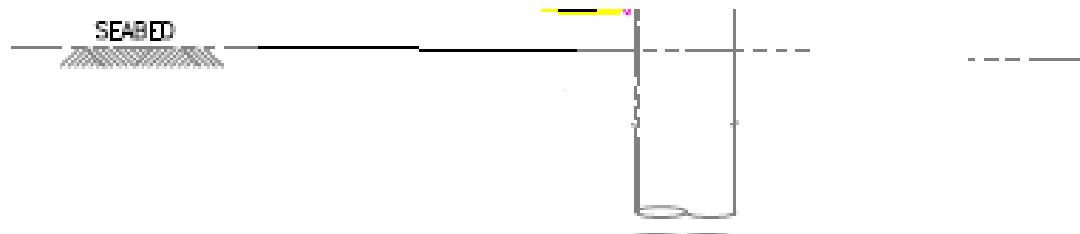
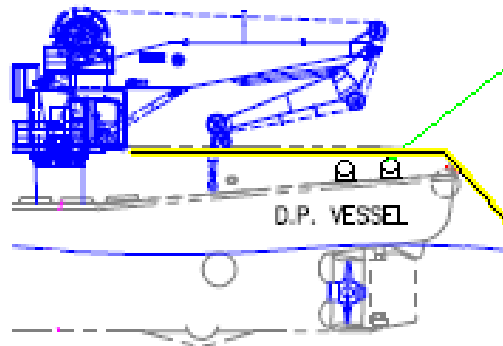

Process weaknesses



- **Safety Issues**
- **Wires under tension on deck**
- **Winch operator is remote from worksite**
- **Frame not safe for personnel WAH**
- **Operational Weaknesses**
- **Frame may swing around on the crane**
- **Frame must be aligned & bolted down**
- **Vessel motion can snap winch wires**
- **Prep work takes 3 hours**

Personnel are exposed to risk of injury

Cable pull in takes significant vessel time

Solution development

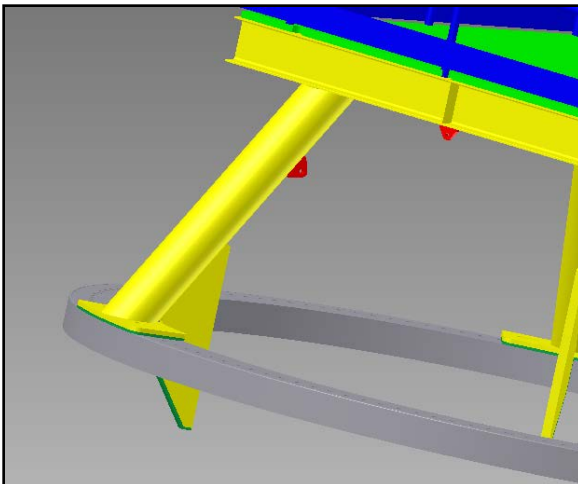
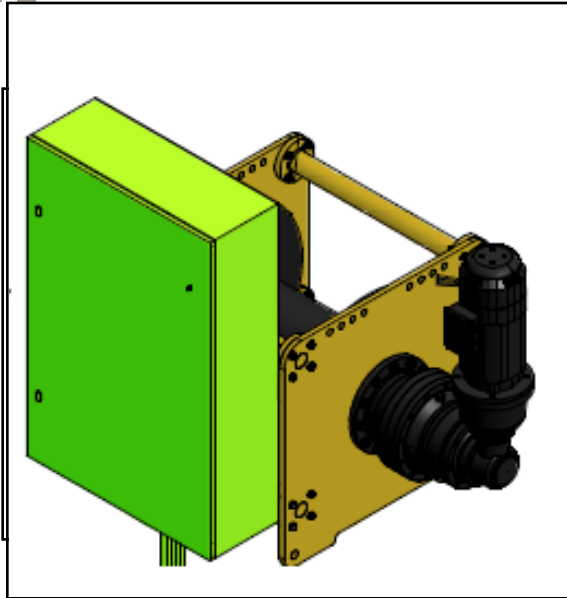

PIM Design Targets

Safety

- Remove Vessel winch wires from operation
- Introduce compliance to industry standards

Operational

- Reduce vessel dependency
- Improve ease of installation
- Onboard equipment storage
- Incorporate power supply for lighting/tools

Improve safety

Save operational time

Patent Filed on behalf of Technip Offshore Wind Limited

TOWL Pull In Module

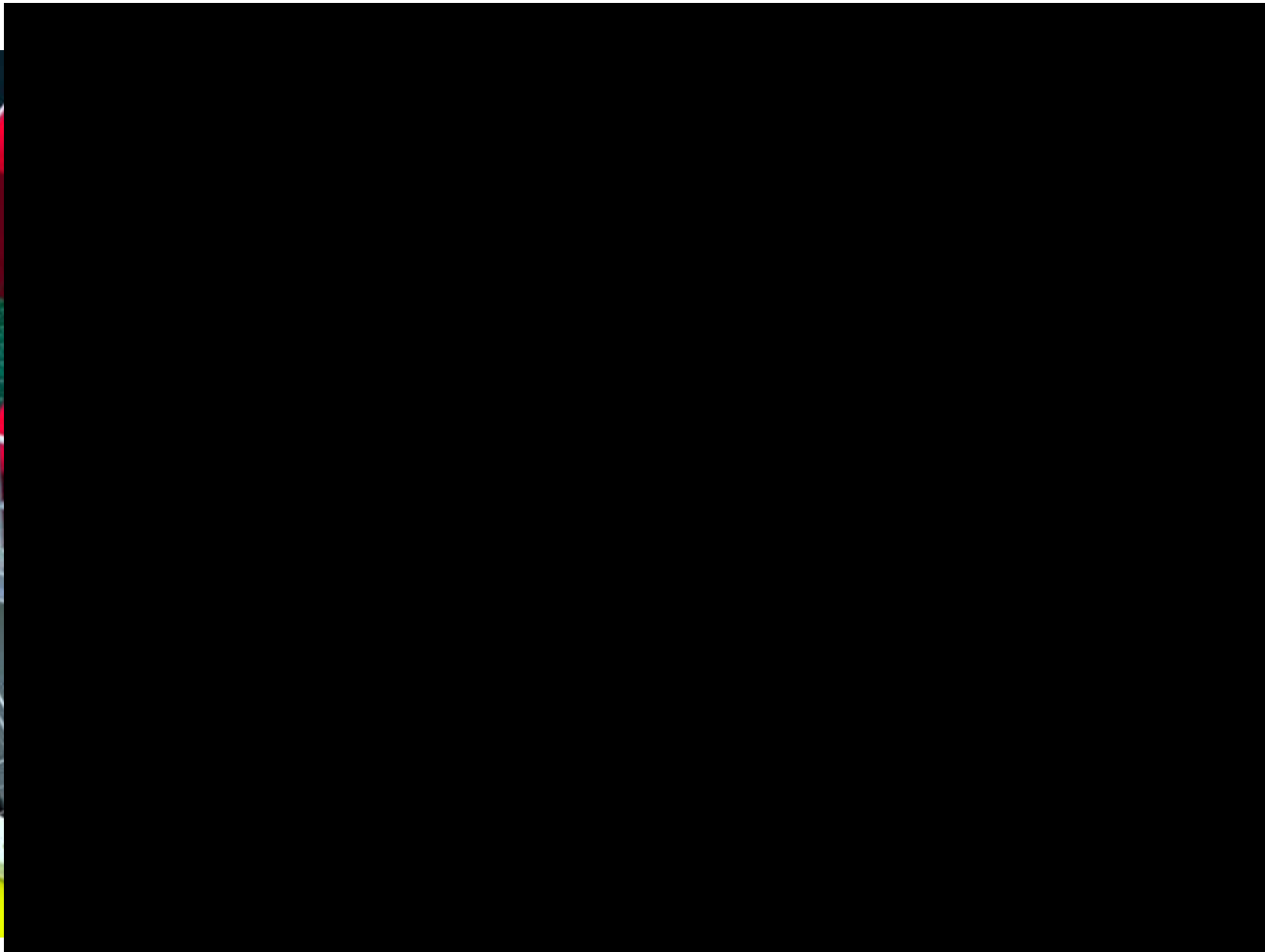

o TP

Patent Filed on behalf of Technip Offshore Wind Limited

Offshore implementation



Patent Filed on behalf of Technip Offshore Wind Limited

Summary



Time saved per pull-in x (2 x No of Turbines in field) = Projected schedule saving
4(hours) x 142 (cable pull ins) = 23.6 vessel days

PIM enables personnel to work safely

Cable pull in completed 60% faster with PIM

Thank you for your time, Any Questions?